



Planning Applications Sub-Committee

Presentation Pack – Part B

Date: MONDAY, 20 NOVEMBER 2023
Time: 1.00 pm
Venue: LIVERY HALL - GUILDHALL

4. **55 AND 65 OLD BROAD STREET, LONDON, EC2M 1RX**
Report of the Planning and Development Director.

For Decision
(pages 99-146)

Ian Thomas CBE
Town Clerk and Chief Executive

This page is intentionally left blank

View 13 - London Wall 3



View 14



Existing view



Proposed view



Proposed + consented

View 15 - Royal Exchange Buildings



Existing view



Proposed view

View 15 - Royal Exchange Buildings



Existing and Proposed views from THVIA

View 16 - Old Broad Street south end



Existing view



Proposed view

View 16 - Old Broad Street south end



Existing and Proposed views from THVIA

View 17 - Liverpool Station, looking south along Old Broad Street



Existing view



Proposed view

View 17 - Liverpool Station, looking south along Old Broad Street



Existing and Proposed views from THVIA

View 18 - New Broad Street, north pavement looking east



Existing view



Proposed view

View 18 - New Broad Street, north pavement looking east

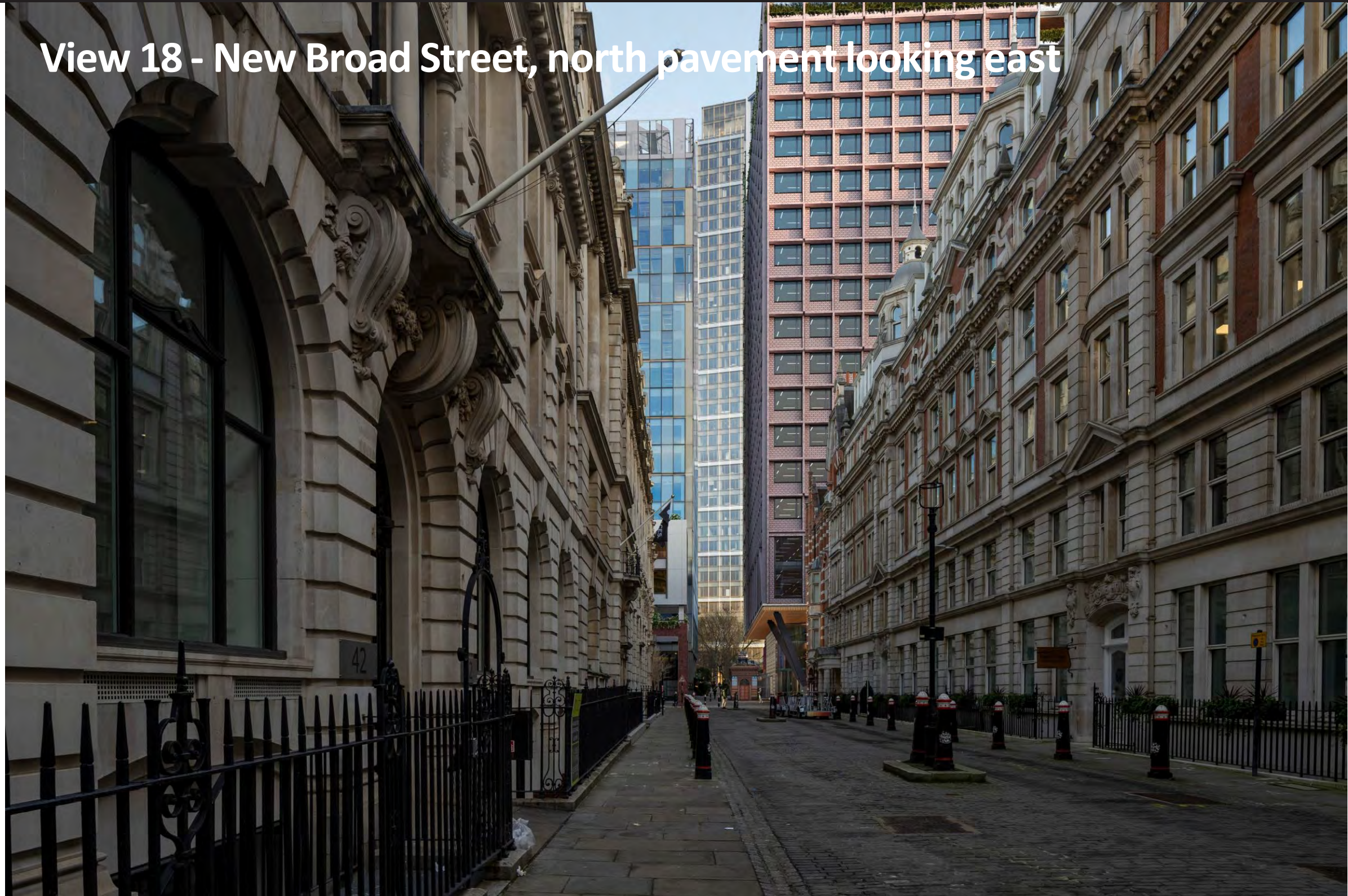

View 19



Existing view



Proposed view

View 19



Existing and Proposed views from THVIA

View 19N - New Broad Street, looking towards Bishopsgate Churchyard



Existing view



Proposed view

View 19N - New Broad Street, looking towards Bishopsgate Churchyard



View 21 - Bishopsgate, east side, near Devonshire



Existing view



Proposed view

View 21 - Bishopsgate, east side, near Devonshire



Existing and Proposed views from THVIA

View 22 - Bishopsgate, east side, at One Bishopsgate Plaza



Existing view



Proposed view



Proposed + consented

View 23 - One Bishopsgate Plaza



Existing view



Proposed view



View 23 - One Bishopsgate Plaza



View 23 - One Bishopsgate Plaza: amended post submission

View 24 - Bishopsgate Churchyard, looking west, winter



Existing view



Proposed view

View 24 - Bishopsgate Churchyard, looking west, winter



View 24N - Bishopsgate Churchyard, looking west, winter, night



Existing view



Proposed view

View 24N - Bishopsgate Churchyard, looking west, winter, night



Existing and Proposed views from THVIA

View 25 - Bishopsgate Churchyard, west of view 24, winter



Existing view



Proposed view



View 25 - Bishopsgate Churchyard, west of view 24, winter

View 28 - Wormwood Street, looking west past site to All Hallows - winter



Existing view



Proposed view

View 28 - Wormwood Street, looking west past site to All Hallows - winter



Existing and Proposed views from THVIA

- ① Roof
- ② Level 22 terrace
- ③ West-facing balcon
- ④ Level 19 communal
- ⑤ Level 20 terrace
- ⑥ Level 20 east-facir
- ⑦ East-facing planter
- ⑧ Level 21 terrace
- ⑨ 65 Old Broad Street
- ⑩ 65 Old Broad Street
- ⑪ 65 Old Broad Street
- ⑫ Public realm landscaping
- ⑬ Level 3 green roof

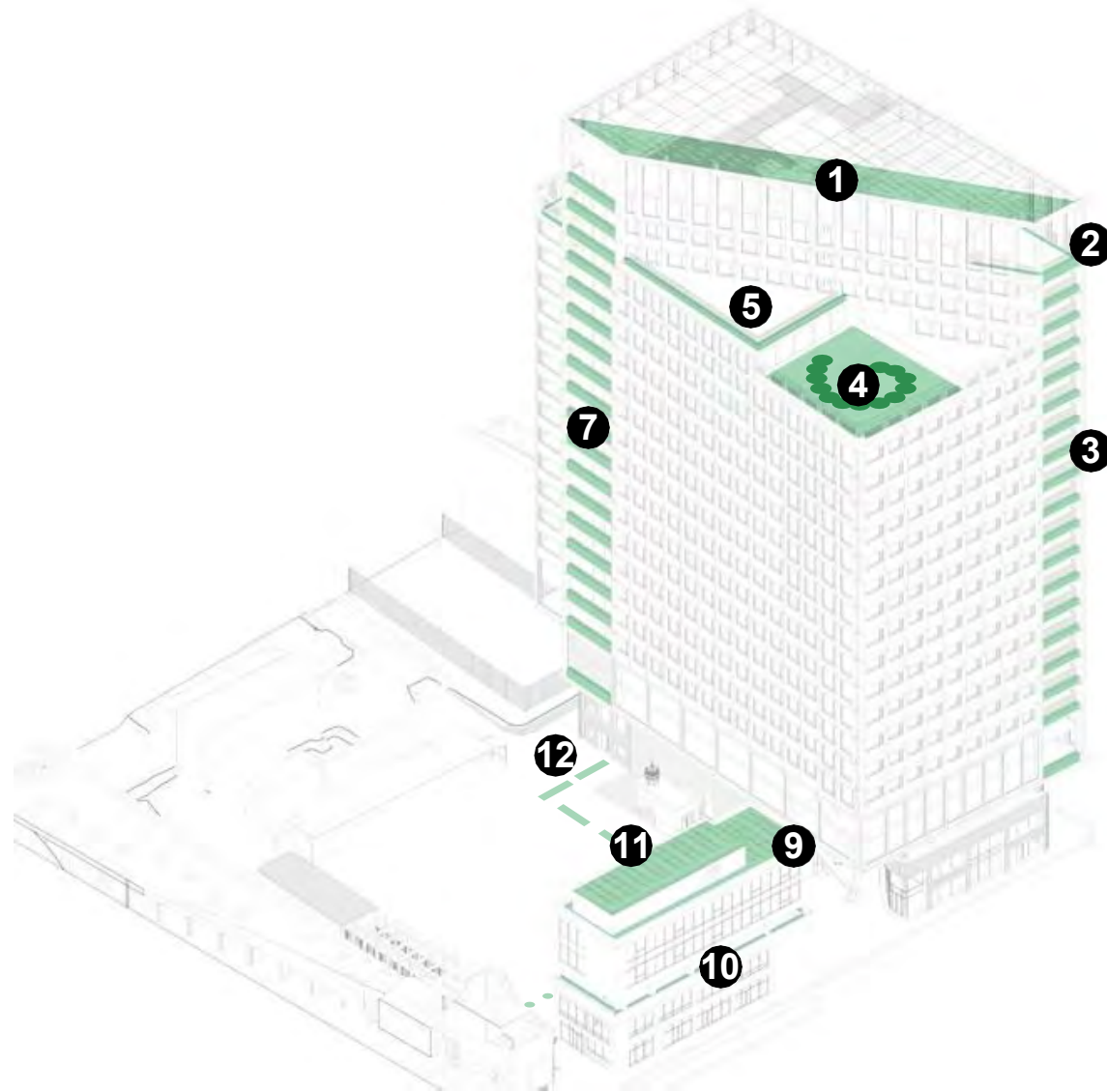

View from northwest

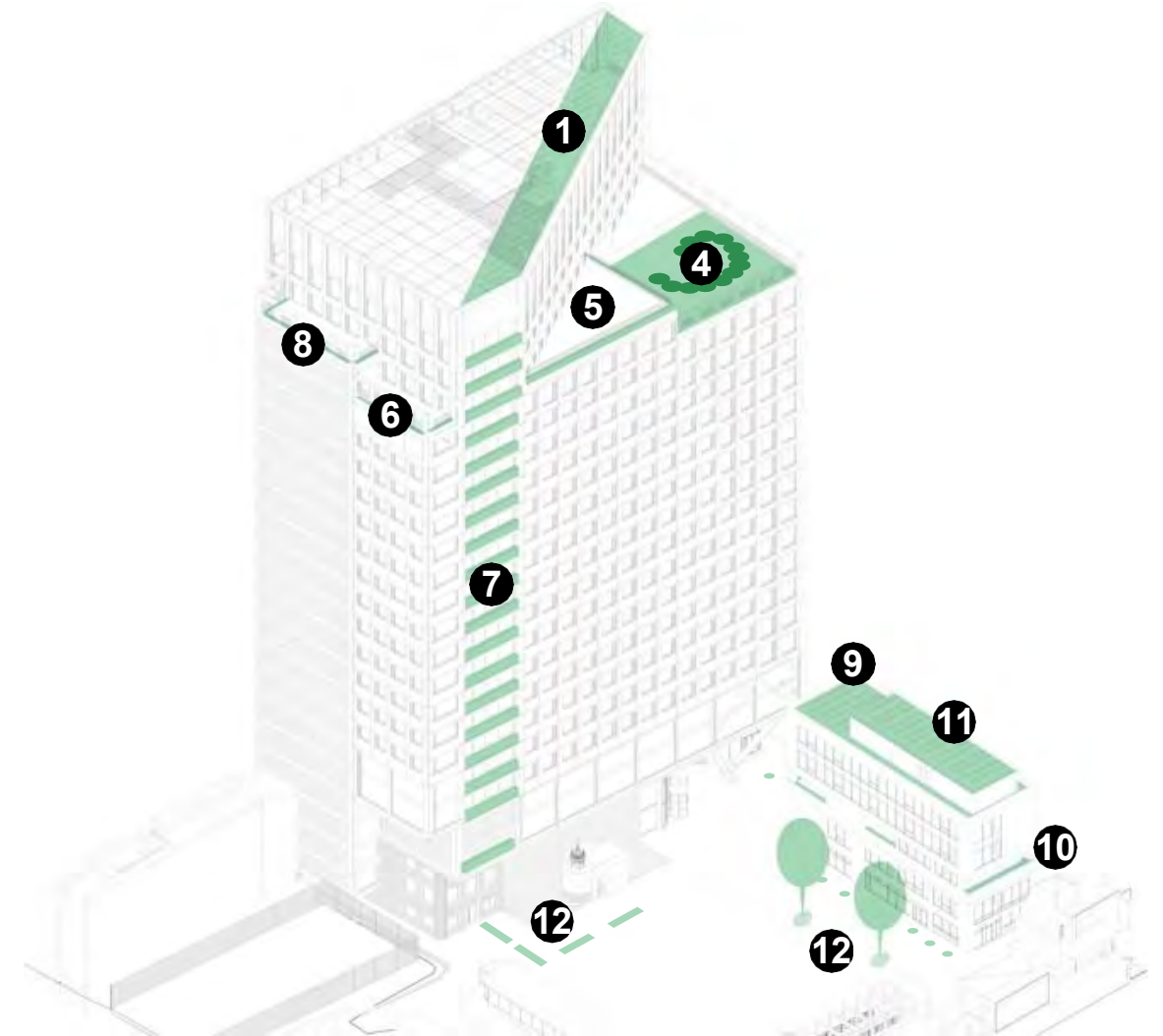

View from northeast

Pedestrian Connectivity Existing Routes

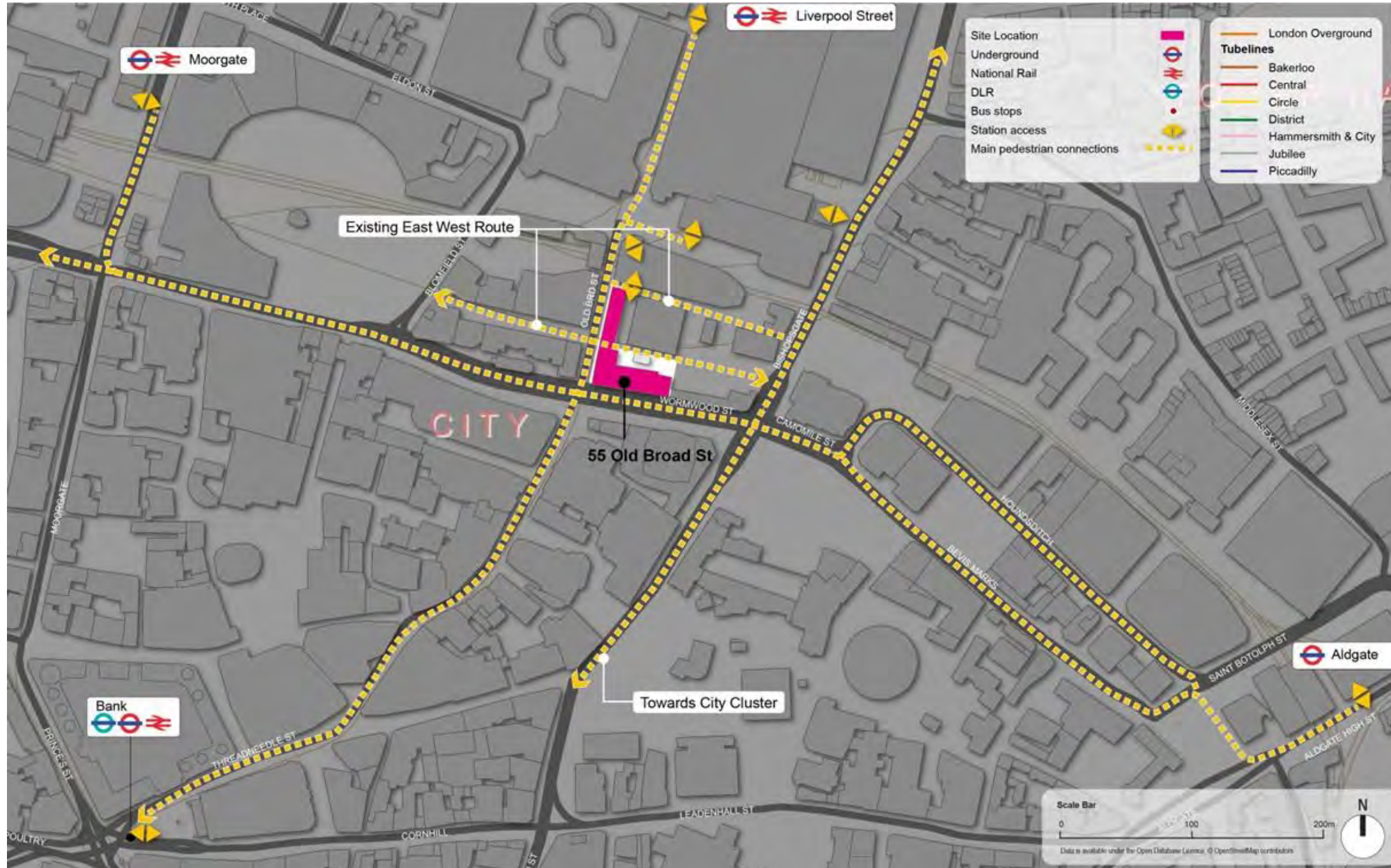

Pedestrian Connectivity Proposed Routes

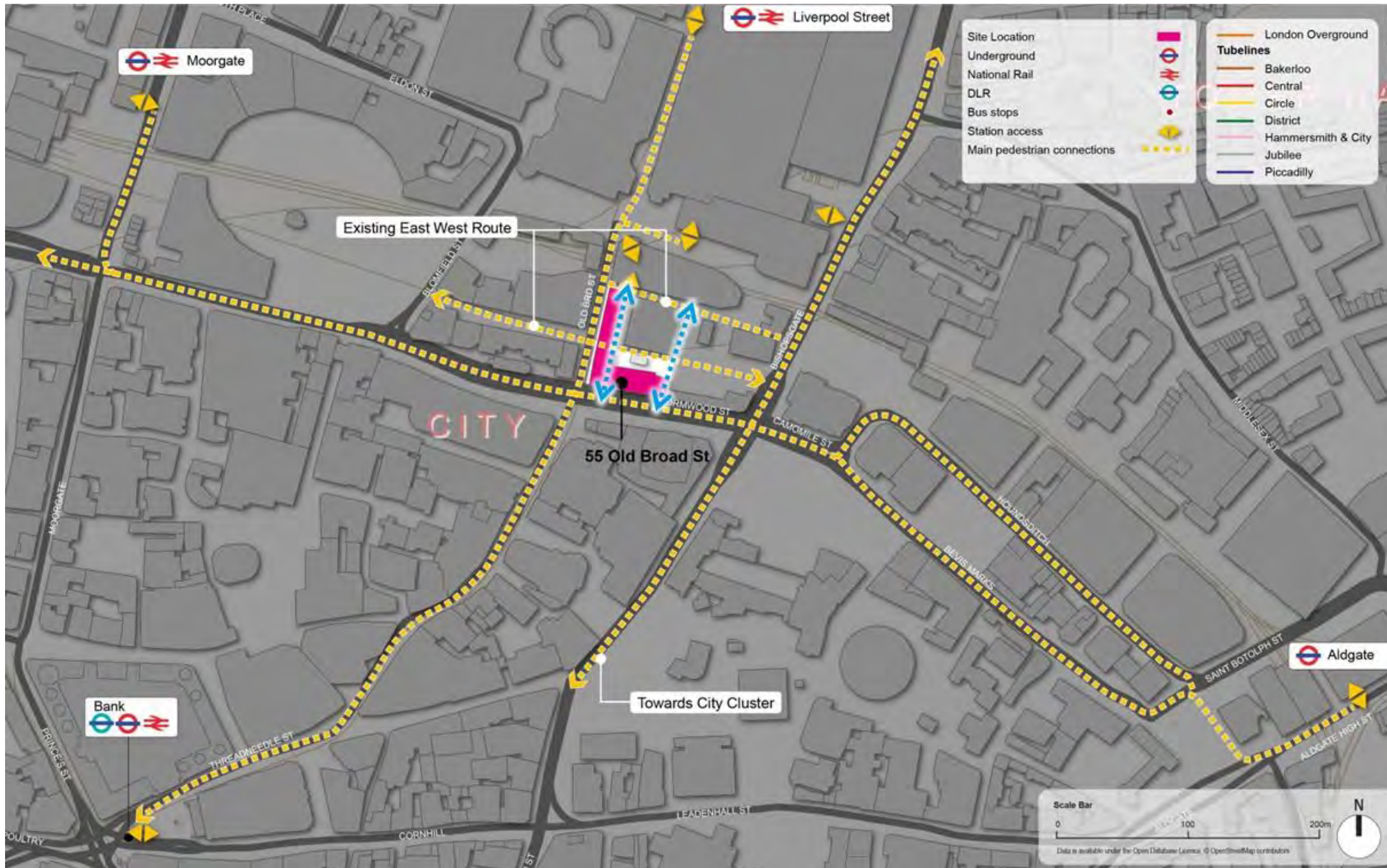

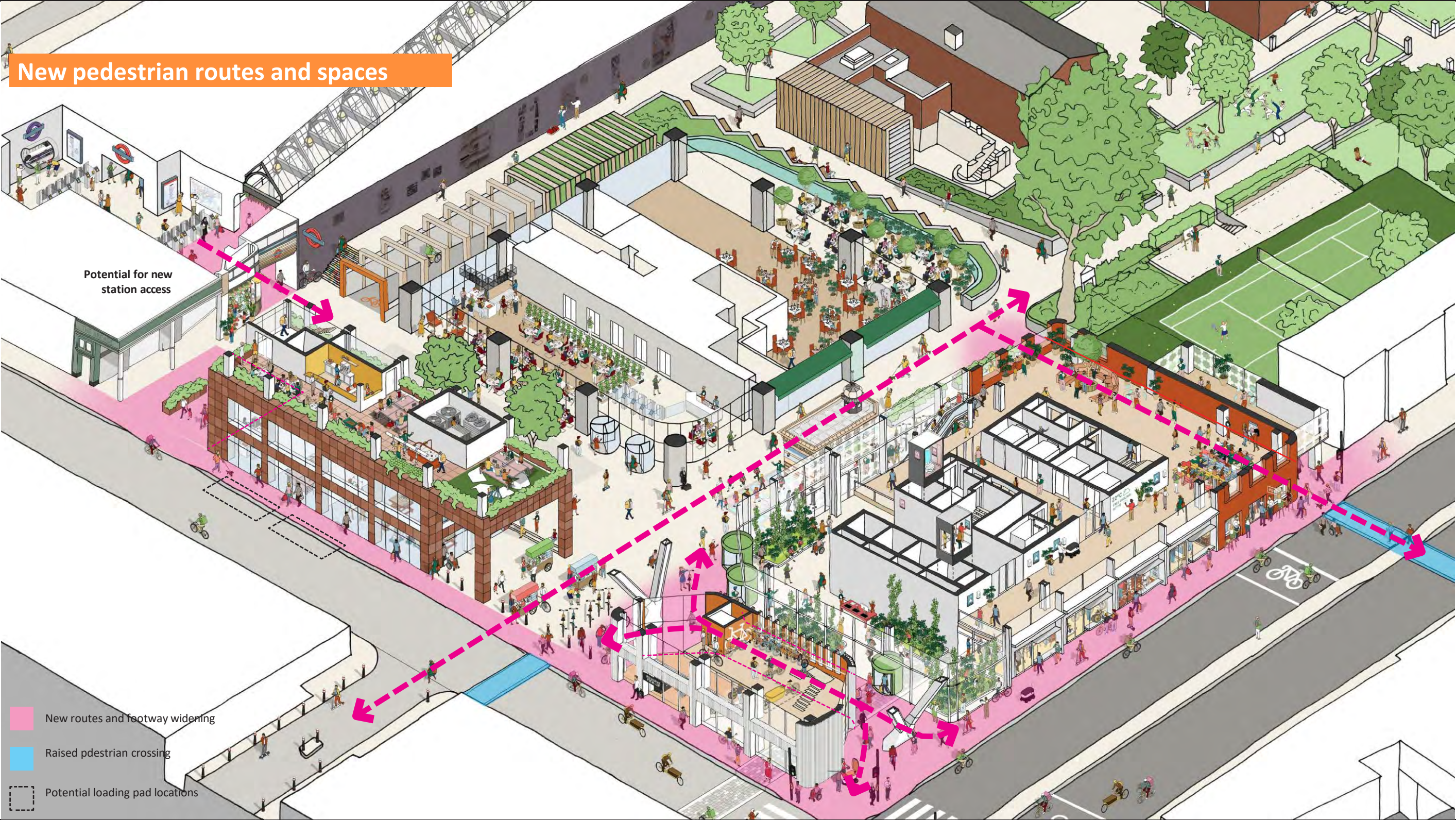

New pedestrian routes and spaces

Potential for new station access

- New routes and footway widening
- Raised pedestrian crossing
- Potential loading pad locations

Pedestrian Comfort

Table 7.17 provides a summary of the PCL scores for the eastern footway of Old Broad Street as well as the proposed north-south pedestrian routes through the Site for the future baseline (2036+).

Link	Clear Footway Width (m)	Future Baseline Flow	AM PCL Peak Score (08:30 – 09:30)
Old Broad Street (Eastern Footway)	1.9	3,707	D
Wormwood Street (northern Footway)	2.4	1,269	B+

Table 7.18 PCL Results - Future With Development AM Peak Hour: Option 1

Therefore, two options have been considered for the future year PCL as set out below:

- Option 1: With footway widening of 1.0m;
- Option 2: No footway widening

Link	Clear Footway Width (m)	Future Baseline Flow	AM Peak PCL Peak Score
Old Broad Street (Eastern Footway)	2.9	1,935	B+
Wormwood Street (northern Footway)	2.4	1,406	B+
Central Route	4.0	2,733	B+
Eastern Route	2.8	335	A+

Table 7.17 Future Baseline Pedestrian Comfort Level Assessment AM Peak

Link	Clear Footway Width (m)	Future Baseline Flow	AM Peak PCL Peak Score
Old Broad Street (Eastern Footway)	1.9	1,935	B-
Wormwood Street (northern Footway)	2.4	1,406	B+
Central Route	4.0	2,733	B+
Eastern Route	2.8	335	A+

Table 7.19 PCL Results - Future With Development AM Peak Hour: Option 2

In line with aims of the City of London Transport Strategy, the delivery and servicing strategy for the Site has been developed to include the use of a consolidation centre to reduce the number of vehicle trips to the Square Mile.

A proposed consolidation factor of 25% has been included in all delivery and servicing forecasts. This is based on typical rates of consolidation achieved for comparable schemes.

This proposed mitigation would ensure that a reduced number of vehicles arrive to the Site during the overnight servicing period.

The unconsolidated (worst-case) delivery and servicing trips are presented in Table 7.15.

Land use	Daily Servicing Trips	Overnight Hourly Trips
Office	54	7
Non-Food Retail	1	0
Restaurant/ Food Retail	9	2
D1 Community / D2 Leisure	0	0
Total*	65	9

Table 7.15 Proposed Delivery and Servicing Trips

Servicing and delivery trips to the Proposed Development will be managed as part of the Framework Delivery and Servicing Plan (DSP). The following measures are included in the DSP to minimise the impact on background road users and reducing the potential for pedestrian and delivery vehicle conflicts:

- A consolidation strategy to be implemented, which is expected to reduce the number of trips by 25 per cent;
- Primarily overnight deliveries from 23:00 to 07:00;
- A delivery booking system;
- Daytime top-up deliveries to be undertaken by cargo bike;
- Traffic calming measures to keep speeds on-site to under 10mph; and
- Introduction of waste compactors at the Site to minimize the number of waste vehicles servicing the Site.

Link	Total Vehicles (18 Hour AADT)					
	2028 Baseline (Without Proposed Development)	2028 (With Proposed Development)	Vehicle Increase	% Change	2028 % HGV	% HGV (With Proposed Development)
Old Broad Street	1,417	1,475	+58	1.09%	38%	38%
Wormwood Street	17,992	18,018	+26	0.14%	13%	13%
Bishopsgate	7,819	7,819	0	0	32%	32%

Table 7.16 Future Baseline vs With Development - Daily (18-hour AADT) Traffic Flows

Building Retention Studies

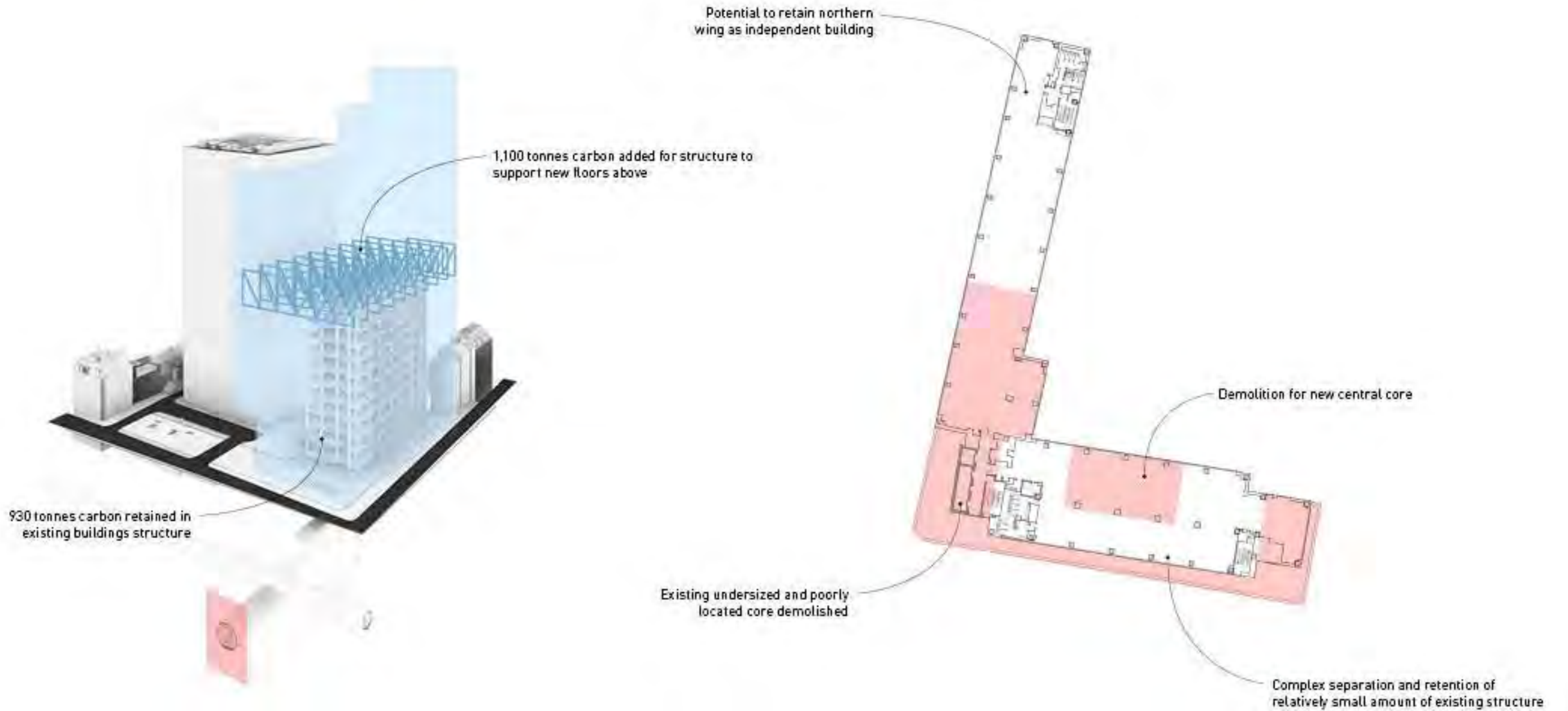

Potential development options

Balanced approach proposed

Existing

Option 1

Option 2

Option 3

Option 4

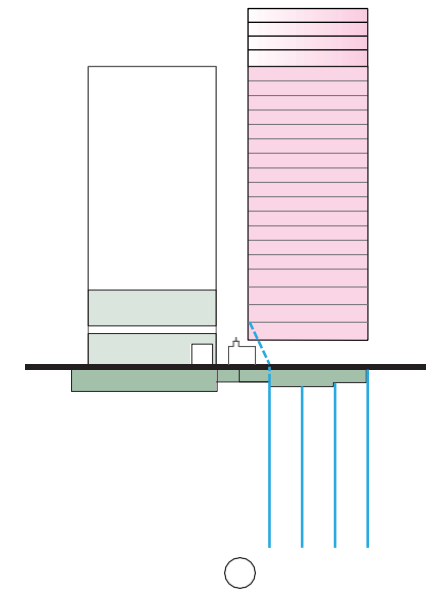
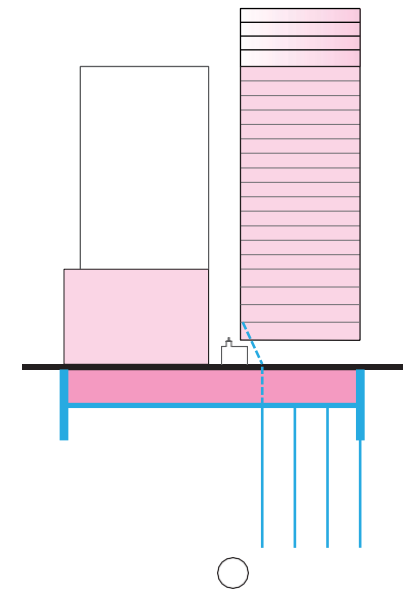
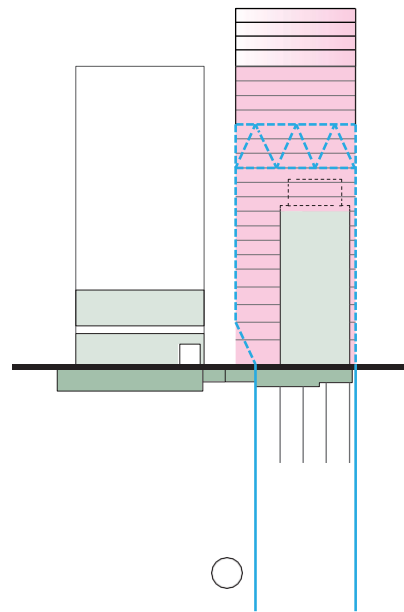
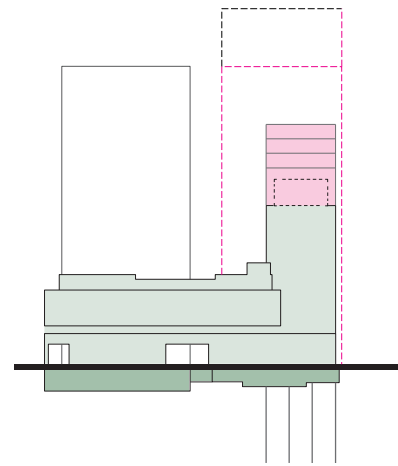
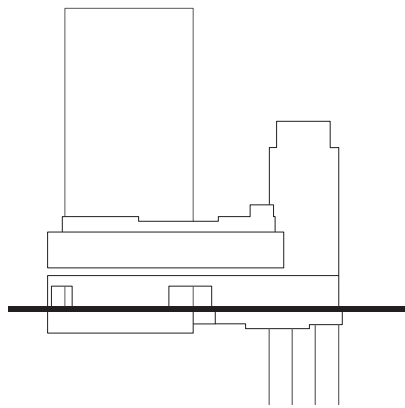
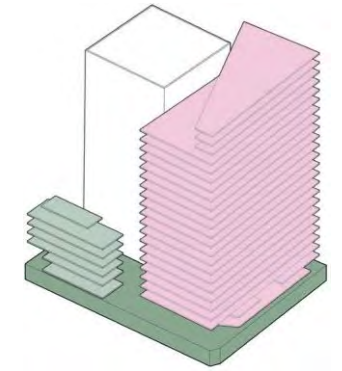
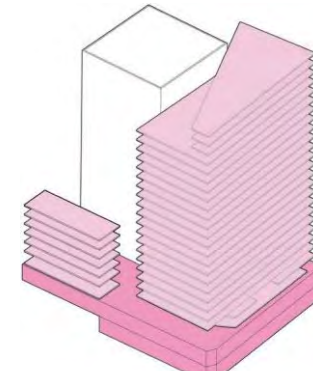
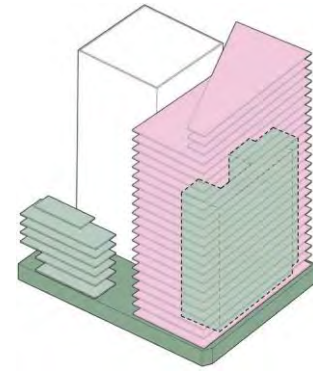
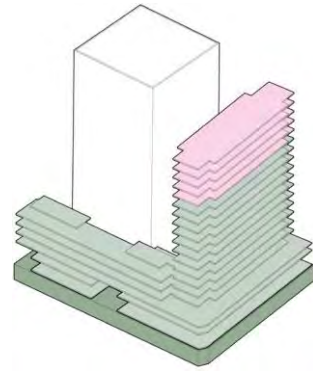
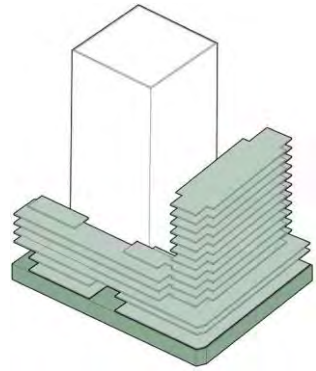

- Retain and refurbish
- New construction
- Major structure
- Potential development envelope
- Below ground tunnels

Carbon payback less than 30 years

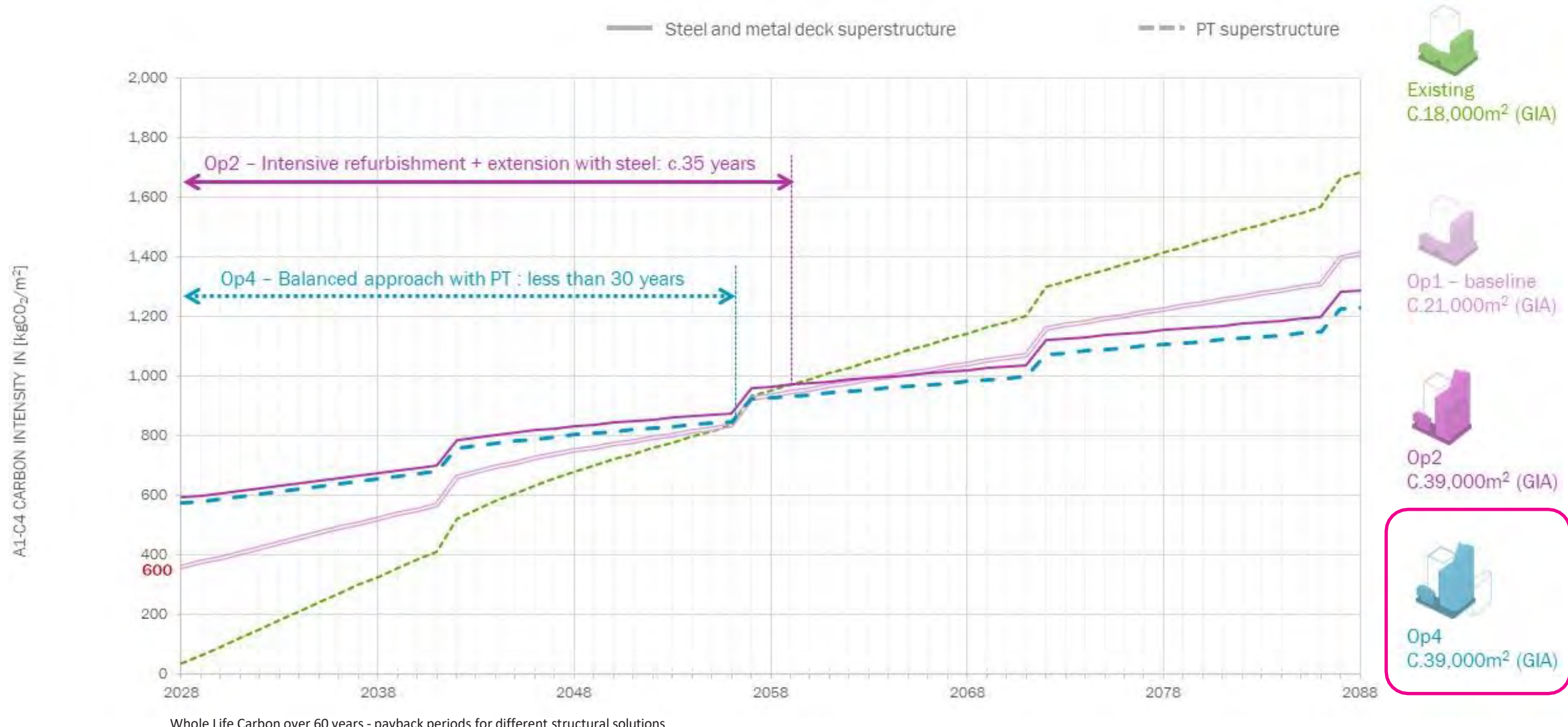

Balanced approach proposed



Maker / studio spaces



65 Old Broad Street: a building retention and reuse exemplar

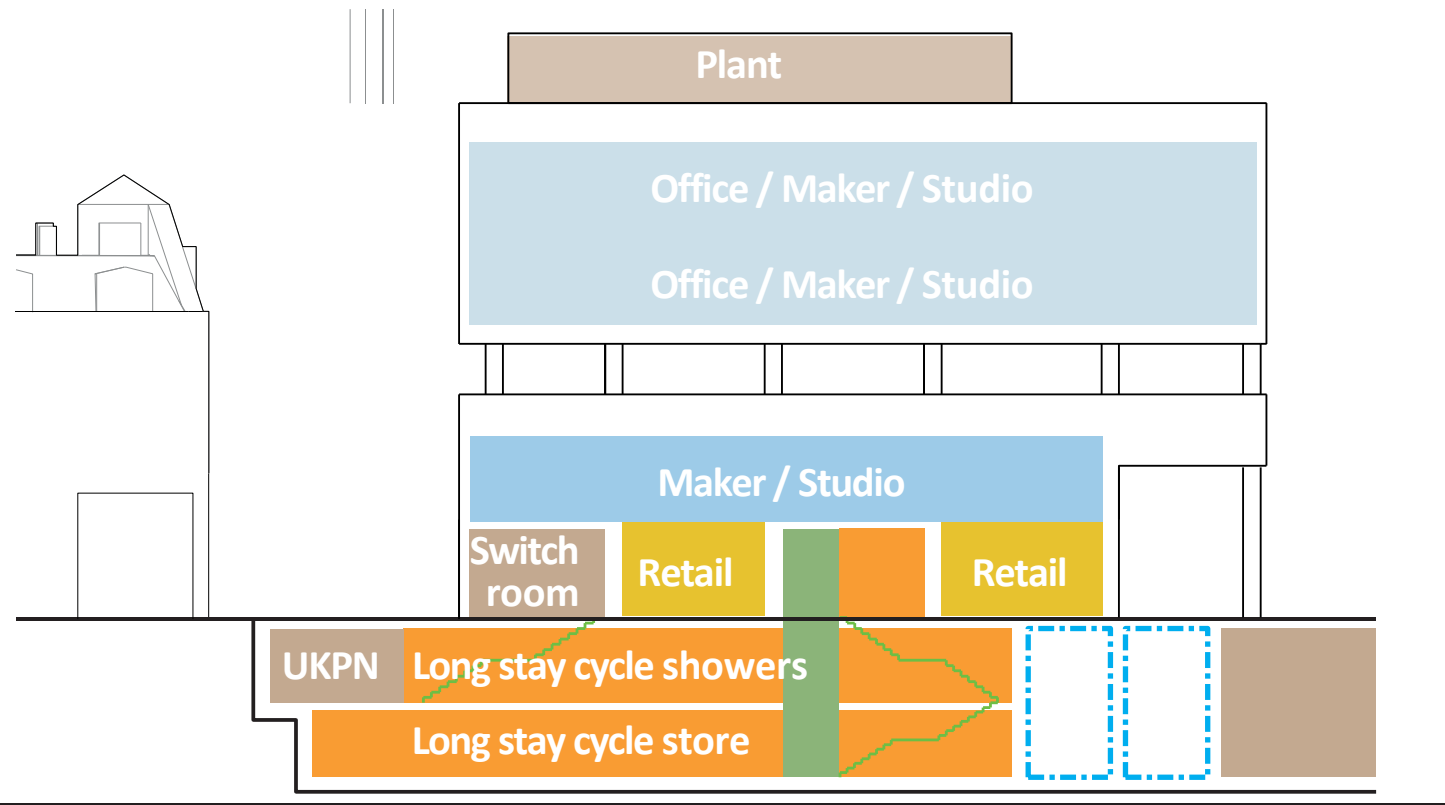

Generative software uses environmental, aesthetic and commercial parameters to help find the most efficient facade solution.

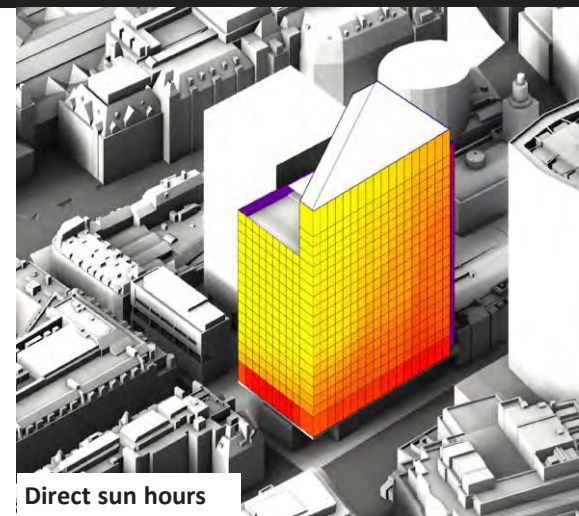
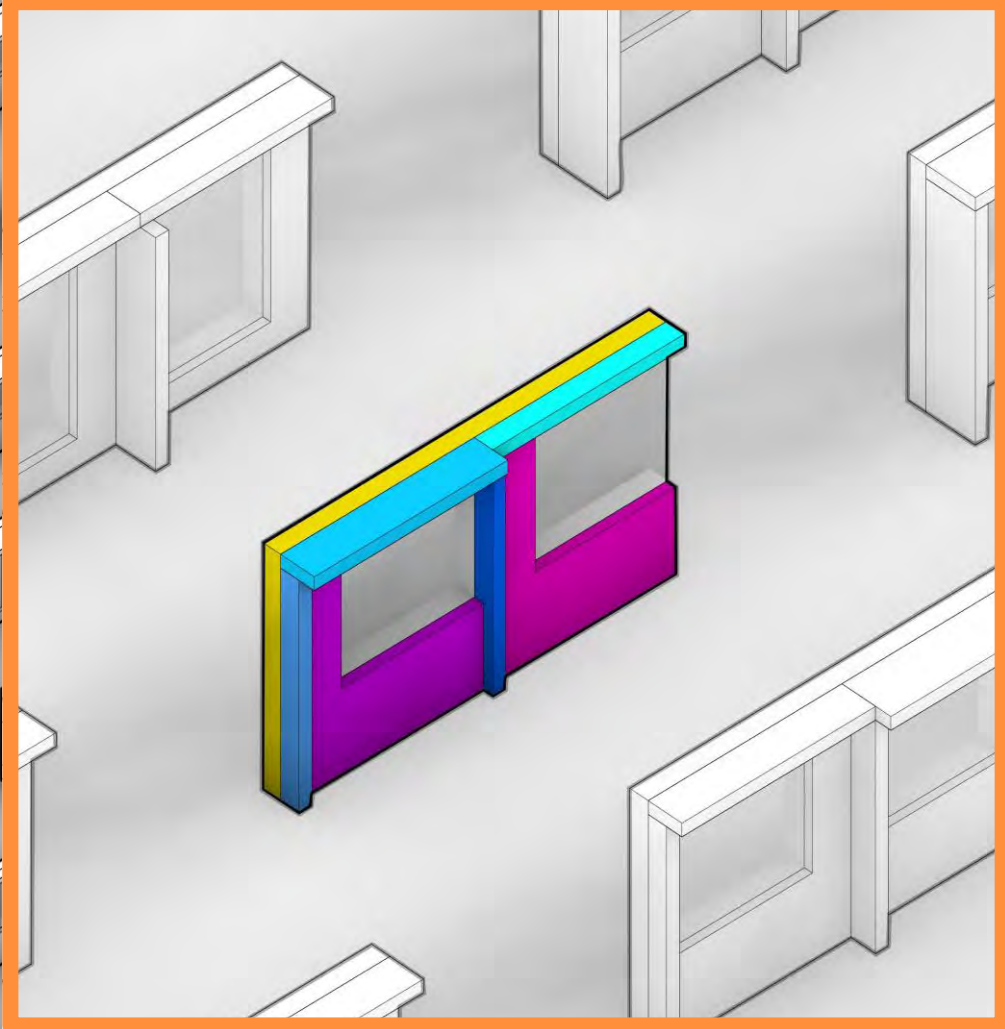

Direct sun hours

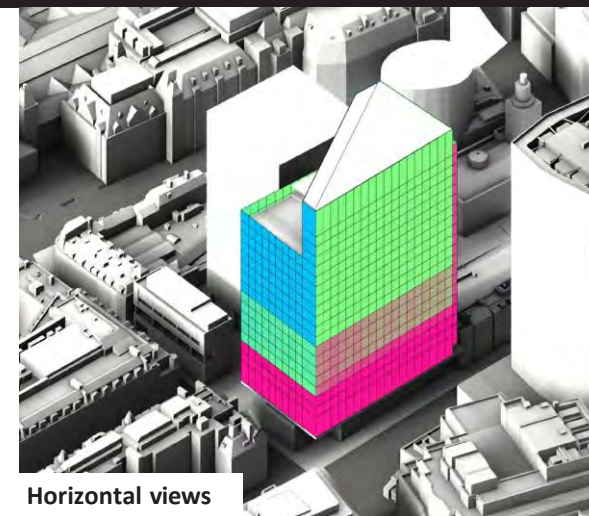

Horizontal views

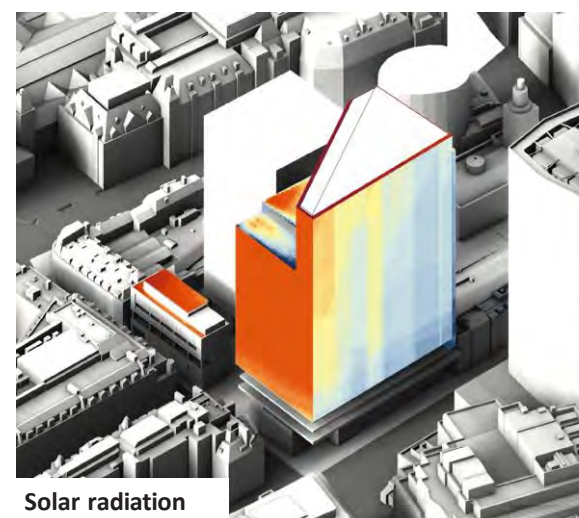

Solar radiation

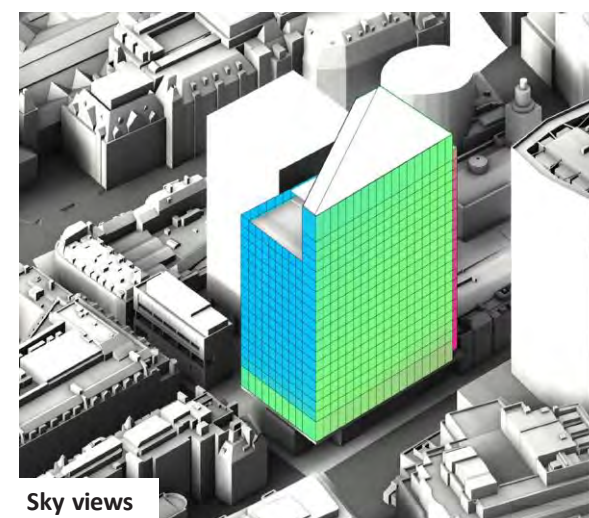

Sky views

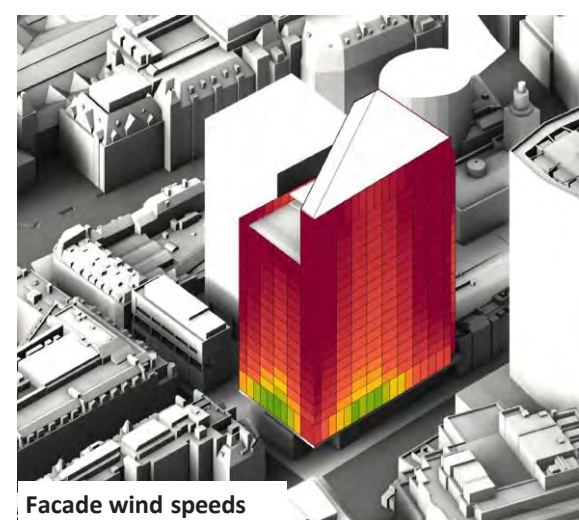

Facade wind speeds

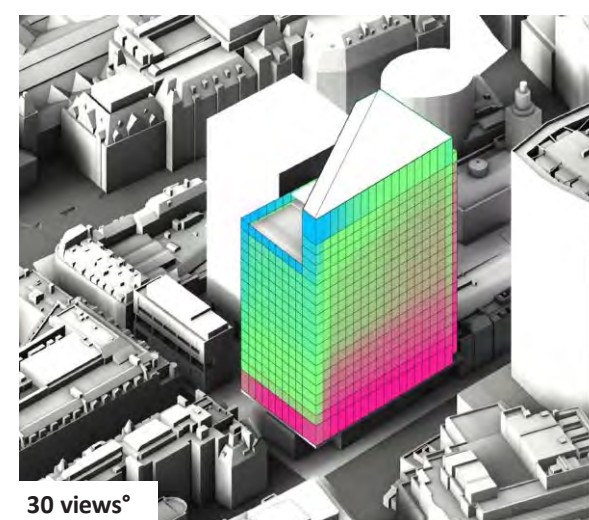

30 views°

50% carbon, over 120+ year design life (vs. unitised facade system)

Naturally ventilated



North elevation



West elevation

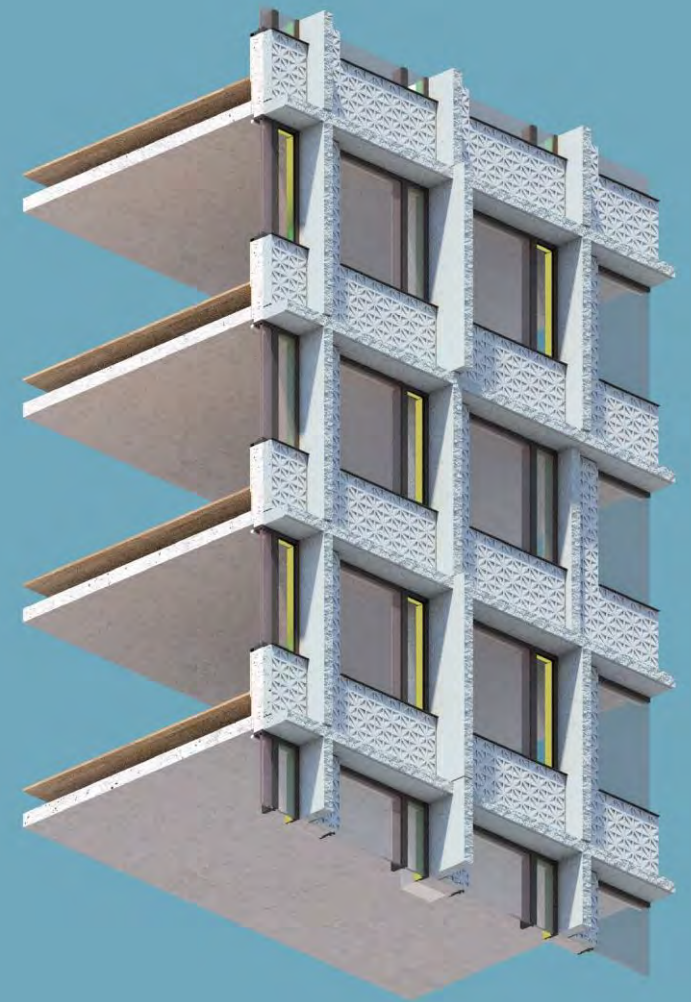

South elevation

Sustainability Summary

BREEAM

The retained 65 Old Broad Street is targeting BREEAM 'Excellent' under BREEAM

Refurbishment and Fit-Out (RFO) 2014 for Offices

The new 55 Old Broad Street is targeting BREEAM 'Excellent' with stretch target of 'Outstanding' under BREEAM New Construction (NC) 2018 for Offices.

Deconstructed/retained

Substructure – 62% volume retention

Superstructure – 25% volume retention

Overall – 28% volume retention

Operational Carbon Savings

Site-wide reduction of 21% beyond Part L 2021. New

55 Old Broad Street building: 2% reduction.

Retained 65 Old Broad Street building: 84% reduction.

For comparison, this is a site-wide reduction of 48% against Part L 2013.

Residual Operational Carbon Emissions

Residual carbon emissions (after application of measures through be lean, be clean, be green hierarchy) are 141 tonnes CO₂ per annum.

Embodied Carbon Emissions

Total up-front embodied carbon of 28,980 tonnesCO₂e (714kgCO₂e per sqm).

This is better than the GLA Benchmark of 950kg/CO₂e per sqm.

Whole Lifecycle Carbon Emissions

Total proposed whole life carbon is 1,072kgCO₂e per sqm.

This is better than the GLA benchmark of 1,400

WLC Optioneering

The following four options were assessed over 60 and 100 year periods. The WLC results for the 60 year periods are below.

Option 1 – light touch refurbishment and limited extension: 812 kgCO₂e per sqm.

Option 2 – extensive refurbishment and maximised extension: 1,052kgCO₂e per sqm.

Option 3 – full demolition and redevelopment: 1,028kgCO₂e per sqm.

Option 4 – partial retention and redevelopment: 977kgCO₂e per sqm.

Option 4 is more favourable than Option 1, because over a 100 year period the operational energy requirements of Option 1 see it surpass the performances of Options 2 and 4. Further, Option 1 does not deliver on the Applicant and City's shared aspiration for transformed public realm and site-permeability, nor the Applicant's aims for a sustainable, adaptable, flexible and market-competitive office building.

Economic

- The provision of 33,078sqm (GIA) of Grade A office floorspace.
- Flexible and publicly accessible cultural uses/event floor space comprising of 320sqm (GIA) in the restored Bath House and 31sqm (GIA) at Level 2 of 65 Old Broad Street.
- The provision of 668sqm (GIA) of office/maker/studio floorspace at Levels 3 and 4 of 65 Old Broad Street.
- Provision of 112 sqm of affordable retail at Level 1 of 65 Old Broad Street.



Environmental

- Significant enhancement of the public realm at ground and higher level including improved environment for pedestrians and cyclists.
- Heritage appreciation of the Grade II Listed Bath House by allowing public access, all which align with Destination City aspirations.



Social

- Enhanced public realm for workers, residents and visitors.
- Learning and educational opportunities associated with the cultural spaces in the restored Bath House and at Level 2 of 65 Old Broad Street.
- The proposed cultural/events spaces will provide potential for the provision for cultural events to bring a new dynamic to the City and facilitate a 7/7 Destination City.

S106 Agreement

- £1,308,676.00 towards affordable housing provision.
- Local Training and Job Brokerage of £785,206.00.
- Public House reprovision.
- Cultural/event space – Bath House.
- Maker/Studio SME Space.
- Affordable Workspace.
- Affordable Retail Space.
- S278 agreement highway improvements.





IMPROVED PUBLIC REALM:
GREENING, PUBLIC ART,
PAVEMENT WIDENING,
WAYFINDING
& PEDESTRIAN
CONNECTIVITY

 **+100SQM**
AFFORDABLE RETAIL

 **£ 12,750**
PROVIDED DIRECTLY
TO EMERGING AND
UNDERREPRESENTED
CREATORS SO FAR

 **+288SQM**
FLEXIBLE
CULTURAL /
EVENT SPACE

 **+290SQM**
MAKER / STUDIO SPACE

70
MORE THAN
ARTISTS/MAKERS
SUPPORTED ANNUALLY

NEW
SECURE CYCLE
STORAGE FOR
THE COMMUNITY

2
NEW CULTURAL
DESTINATIONS
FOR THE CITY

EMPLOYABILITY AND SKILLS
DEVELOPMENT OPPORTUNITIES
THROUGH CONSTRUCTION

31
ARTISTS ALREADY
EXHIBITED
@ 65 OLD BROAD
STREET

490SQM  **+25** 
FLEXIBLE MAKER/STUDIO/SME WORKSPACE INCLUDING AFFORDABLE DESKS



Proposed Scheme Overview



Architectural Impressions – Old Broad Street



Next Planning & Transportation Committee

8th December 2023

This page is intentionally left blank